

# Leo 15GT

Compact & capable  
all-rounder.

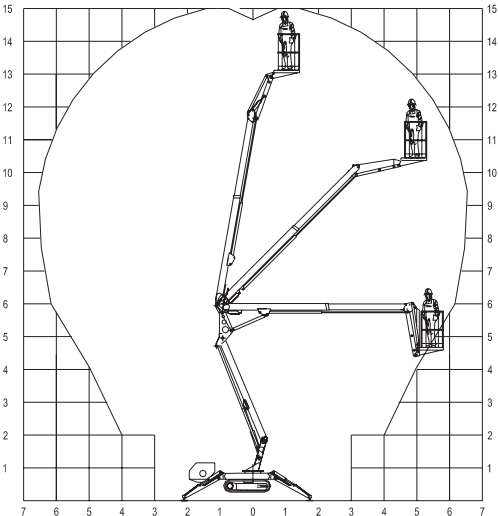

- Dual power source - mains electric or diesel - can work indoors or out
- Height & width adjustable crawler tracks - great ground clearance for rough terrain
- Removable cage gives compact transport dimensions



**HigherAccess**  
Spider Lift Hire Specialists

08456 044 054 [www.higheraccess.co.uk](http://www.higheraccess.co.uk)

# Leo 15GT

Working Height (max.)	14.90m
Platform Height (max.)	12.90m
Lateral Outreach (max.)	6.40m
Safe Load on Cage (max.)	200kg
Cage Rotation	None
Range of Rotation	355°
Limited Range of Rotation - one side narrow	Not Possible
Limited Range of Rotation - both sides narrow	Not Possible
Cage Dimensions (L x W x H) (m)	1.2 x 0.7 x 1.1m
Removable Cage	Y
Length in Travelling Position with Cage (min.)	4.71m
Length in Travelling Position without Cage (min.)	4.00m
Width in Travelling Position with Cage (min.)	1.20m
Width in Travelling Position without Cage (min.)	0.78m
Height in Travelling Position (min.)	1.995m
Net Weight	1,952kg
Setup Width - Standard - to outside edge of outrigger pad	2.9m
Setup Length - Standard - to outside edge of outrigger pad	3.9m
Setup Width - One Side Narrow - to outside edge of outrigger pad	Not Possible
Setup Width - Both Sides Narrow - to outside edge of outrigger pad	Not Possible
Power Supply	Diesel
	240V Electric
Climbing Ability	28°
Setup Ability	10°
Maximum Point Load (N)	11,550
Load on 400mm Pad (N/cm <sup>2</sup> )	7.219
Load on 600mm Pad (N/cm <sup>2</sup> )	3.208
Load on 800mm Pad (N/cm <sup>2</sup> )	1.805
Live Load in Setup Position (KN/m <sup>2</sup> )	1.735
Traffic Live Load (KN/m <sup>2</sup> )	5.341
Drive Control	From basket
Drive Speed	1.50km/h

## DISCLAIMER

The information on this page is for guidance only and is subject to change without prior notice in line with the Manufacturer's Development Program. Higher Access and its suppliers cannot be held liable for any damage or injury sustained through use of this information to specify equipment.